

# Screw Air Compressor

## User Manual



*Before installing or starting the compressor for the first time, please read this manual carefully to understand the relevant knowledge of the compressor and the precautions for operation and maintenance.*

*Please hand over this manual to the user together with the machine.*

*This technical manual contains important safety information, which should be kept with the compressor at all times.*

# List

---

<b>1、 Product Description.....</b>	<b>2</b>
<b>2、 Working Principle.....</b>	<b>4</b>
<b>3、 Main Structure.....</b>	<b>5</b>
<b>4、 Pipeline Flow Chart.....</b>	<b>6</b>
<b>5、 Electrical Schematic Diagram .....</b>	<b>7</b>
<b>6、 Basic Operation and Parameter Setting of Fixed Speed Controller .....</b>	<b>9</b>
<b>7、 Basic Operation and Parameter Setting of Variable Speed Controller.....</b>	<b>16</b>
<b>8、 Warnings and Precautions.....</b>	<b>34</b>
<b>9、 Equipment Installation.....</b>	<b>36</b>
<b>10、 Equipment Operation.....</b>	<b>37</b>
<b>11、 Use and Maintenance.....</b>	<b>39</b>
<b>12、 Troubleshooting.....</b>	<b>44</b>

# 1 Product Description

## 1. Description of compressor

The screw compressor of our company is the result of years of research and development. The combination of these prerequisites and high quality standards can guarantee the long life, high reliability and high operating efficiency of the manufactured screw compressor. Products can meet all environmental protection requirements.

### Use range

This series of machines and units are produced in accordance with mature technology and recognized safety rules. However, if the following situations occur, it may still threaten the lives and limbs of the user or a third party, or cause damage to the machine and other material properties:

#### Incorrect usage range

Operated by unqualified personnel

Unreasonably modify or change the machine

Not following safety rules

Therefore, anyone who has the right to operate, maintain or repair the machine must read and follow the safety regulations. If necessary, a signature can be required to confirm this.

In addition, it must also comply with:

Related accident prevention rules

Accepted safety regulations

National regulations

This series of machines and units must be used under perfect technical conditions, and must be used in accordance with the scope of use and guidelines specified in the operation manual. The users must have safety awareness and fully understand the dangers in operating the machine. If any functional failure occurs, especially the failure that affects safety, it must be repaired in time (or ask someone to repair it)!

*The meaning of operating the machine within the scope of use also includes compliance with certain guidelines in the operating manual and inspection and maintenance as needed.*

## **Maintenance**

The machine must be carefully maintained so that the screw compressor or compressor unit can meet various requirements. Therefore, the machine must be carefully maintained according to the prescribed maintenance period, especially in the case of poor working environment.

## **Service**

In the event of a malfunction or need spare parts, please contact the company's compressor dealer. If the equipment is damaged, our company's well-trained maintenance personnel will use our company's original parts to provide quick and good repair services. The authentic spare parts of our company are manufactured with the most mature technology, which can ensure the reliable operation of the machine.

## **Guarantee**

Before operating the machine, you must understand the machine and related instructions exactly. If the use of this machine does not match the scope of application, or the purpose of use exceeds the scope mentioned in this manual, the company will not be responsible for the safety of the operation.

In the following cases, our company will not accept guarantee claims:

Operation error

Improper maintenance

Misuse of accessories

Do not use the company's original accessories

Modify or modify this equipment

The company will not expand the general terms of guarantee and compensation conditions due to the above description.

Any unauthorized modification of the compressor or compressor station, or installation of components that are not approved by the manufacturer, will not accept claims or guarantee requirements.

## **Safety Regulations**

The safety regulations in the operating instructions must be strictly followed.

## **Technical Changes**

During the technological development process, we reserve the right to modify the parts without notice.

*Note: If you have any needs, please feel free to contact our company's local service provider, we will provide you with more services.*

## 2 Working Principle

The complete working cycle of the screw air compressor can be divided into three processes: suction, compression and exhaust. As the rotor rotates, each pair of meshing teeth completes the same working cycle one after another. For simplicity and clarity, we are here to study the entire working process of a pair of gears.

a) Suction process: When the rotor starts to rotate, one end of the gear is gradually disengaged to form a volume between gears. The expansion of the volume between the gears creates a certain vacuum in its interior, and the volume between the gears is only related to the suction. The air ports are connected, so air flows into it under the action of the pressure difference. During the subsequent rotation of the rotor, the gears of the male rotor are continuously separated from the gear grooves of the female rotor, and the volume between the gears will not increase. Here is disconnected from the suction port, the air is enclosed between the gears, and the suction process ends.

b) Compression process: As the rotor rotates, the volume between gears is continuously reduced due to the meshing of the rotating teeth. The volume occupied by the air enclosed in the volume between the gears is also reduced, resulting in an increase in pressure, thereby realizing the air compression process.

c) Exhaust process: With the continuous reduction of the volume between the gears, the gas with exhaust pressure is continuously transported to the exhaust port to be exhausted. This process continues until the end profile is completely meshed. At this time, the compressed air in the volume between the gears is completely exhausted through the exhaust orifice, the volume of the closed volume between the gears becomes zero, and the exhaust process is completed.

① Inspiratory Process

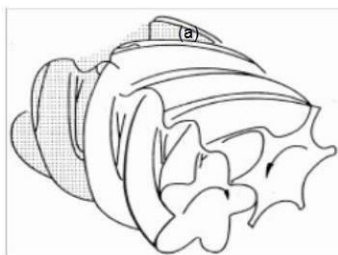

② Enclosed and transported

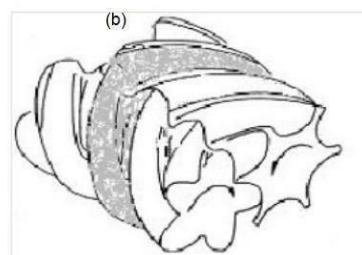

③ Compression and Injection

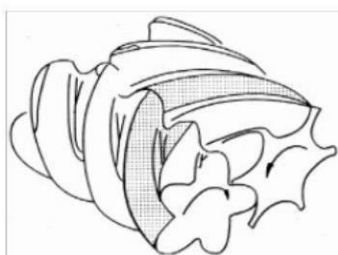

④ Exhaust process

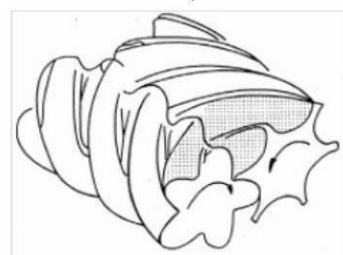

### 3 Main Structure

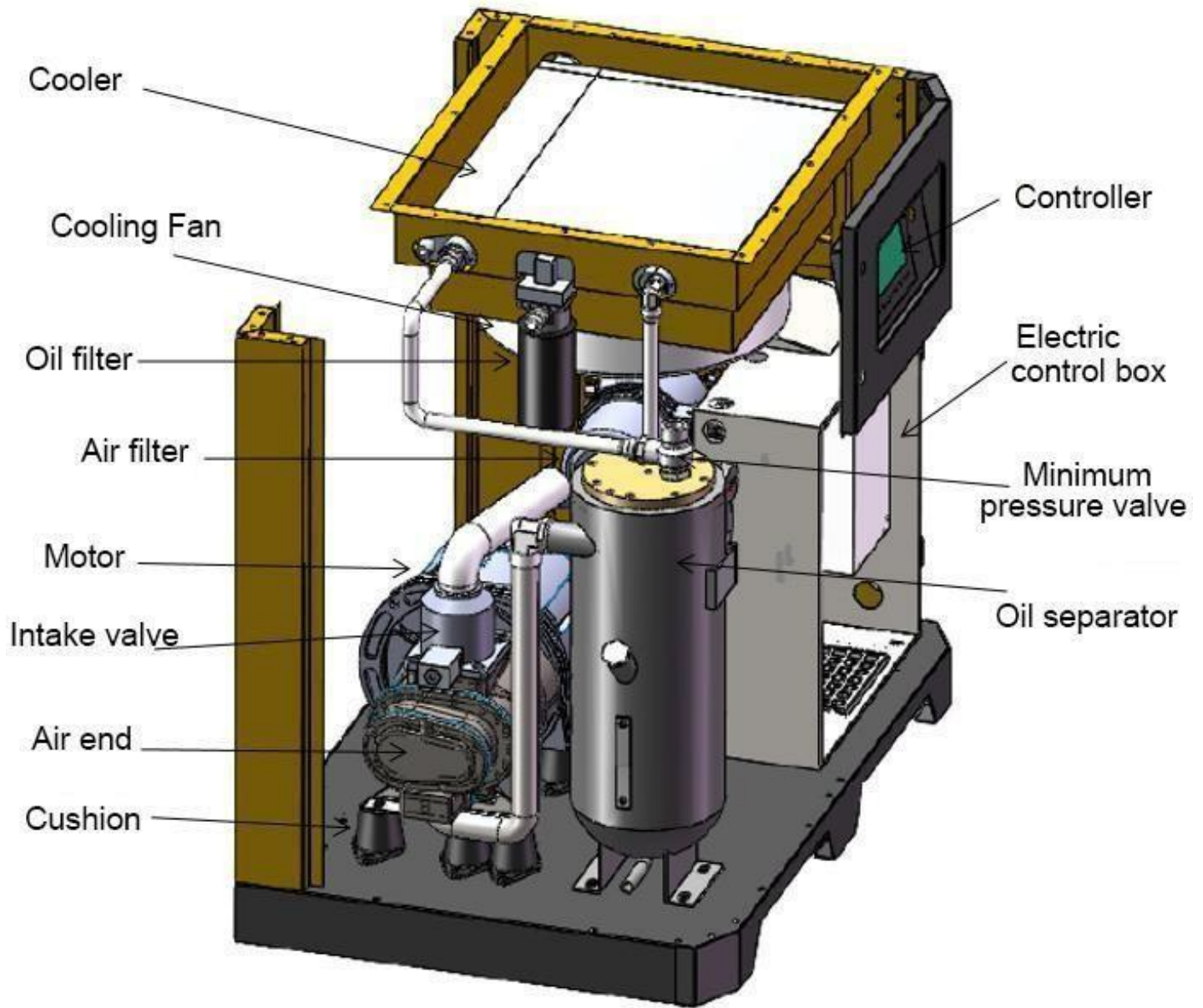

Picture 3.1 --Integrated screw machine

# 4 Pipeline Flow Chart

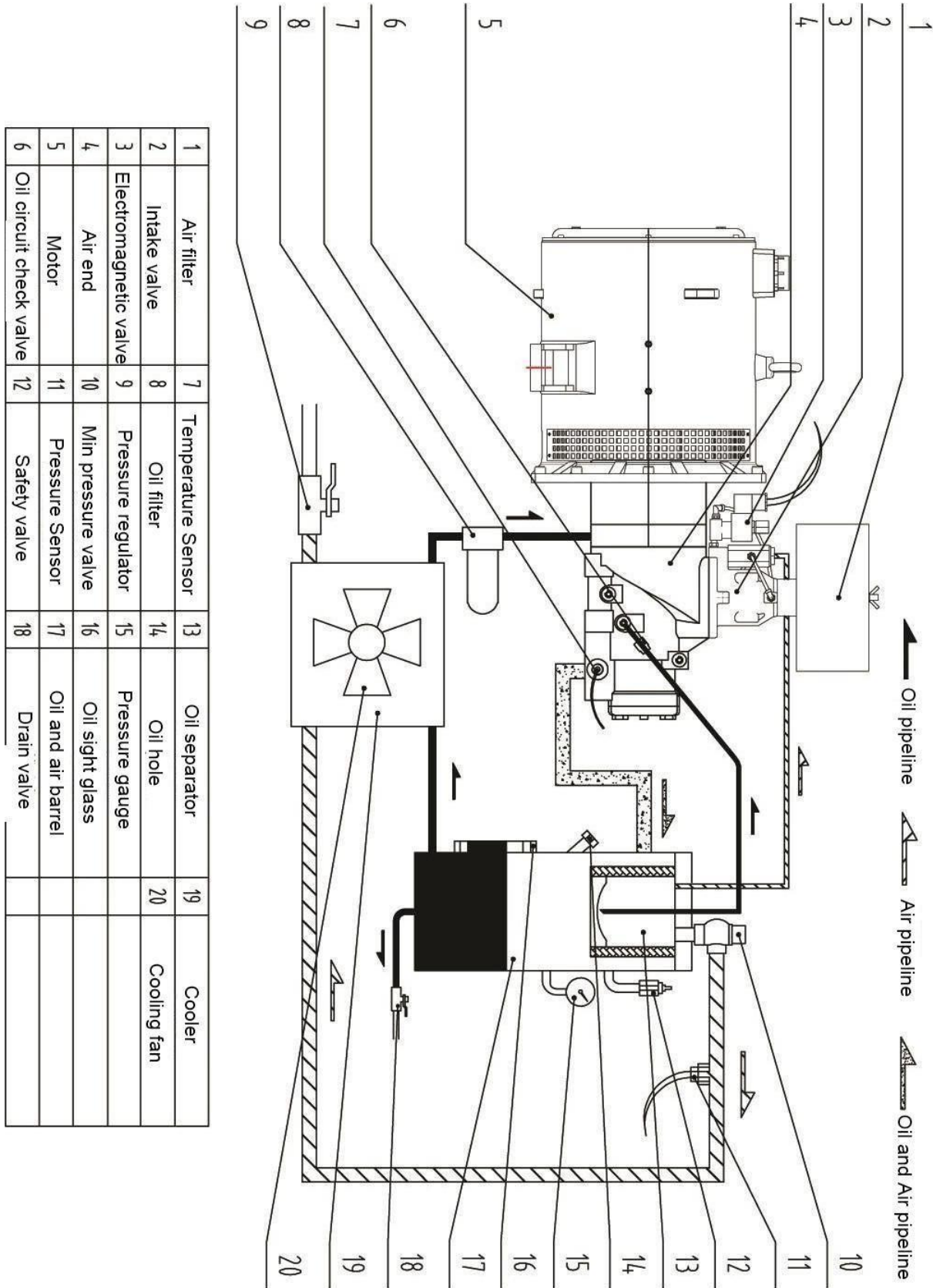

Picture 4.1-- Flow chart of direct-coupled integrated screw machine

Sr.No	Part Name	Part Code
1	Air Filter	AF031
2	Intake Valve	IV032
3	Electromagnetic Valve	EV033
4	Air End	AE034
5	Motor	M035
6	Oil Circuit Check valve	OV036
7	Temperature Sensor	TS037
8	Oil Filter	OF038
9	Pressure Regulator	PR039
10	Minimum Pressure Valve	MPV0310
11	Pressure Sensor	PS0311
12	Safety Valve	SV0312
13	Oil Separator	OS0313
14	Oil Hole	OH0314
15	Pressure Gauge	PS0315
16	Oil Slight Glass	OG0316
17	Oil & Air Barrel	OB0317
18	Drain Valve	DV0318
19	Cooler	C0319
20	Cooling Fan	CF0320



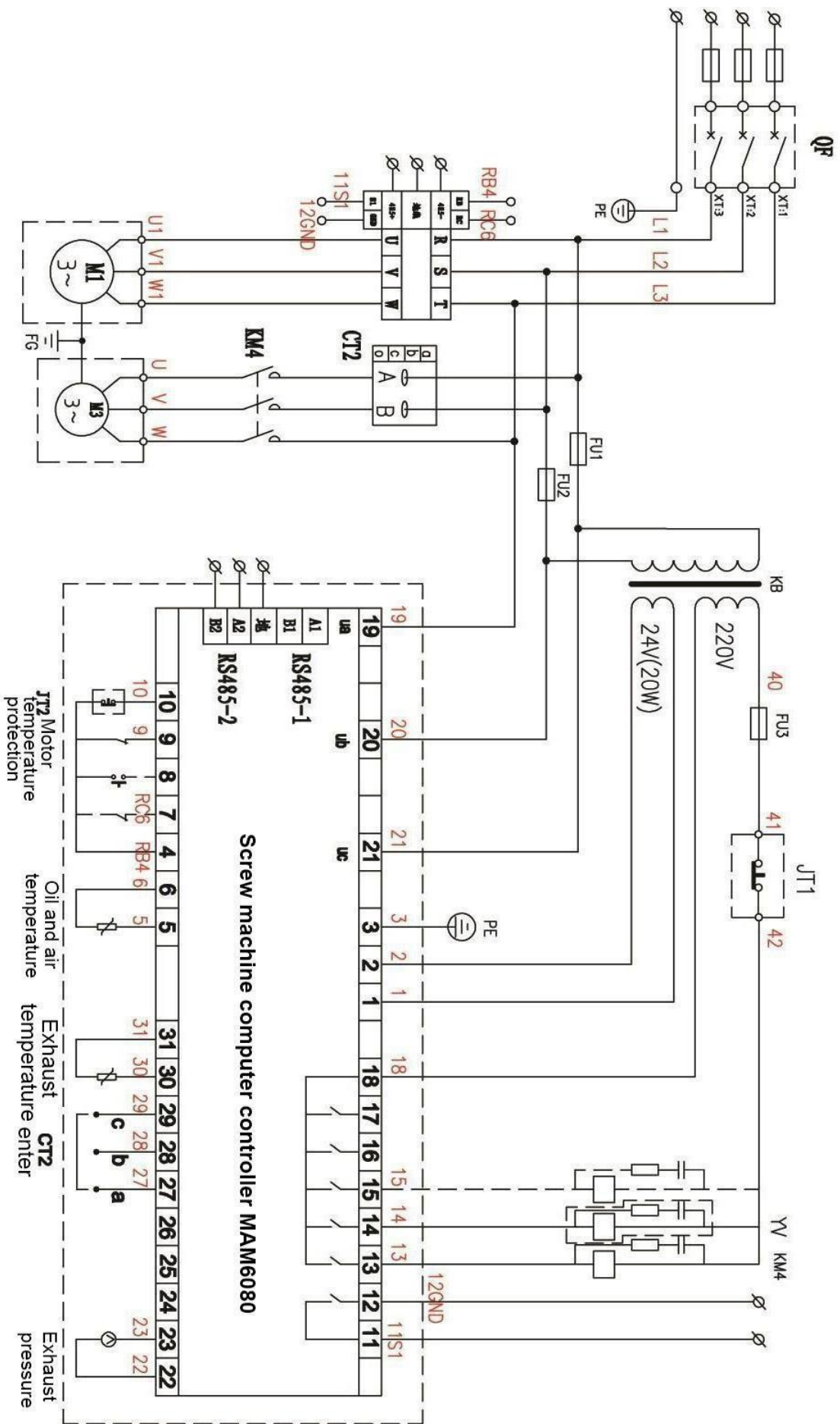

Picture 5.2--PM variable speed electrical schematic diagram

# 6 Basic Operation and Parameter Setting of Fixed Speed Controller

## 1、 Button Description

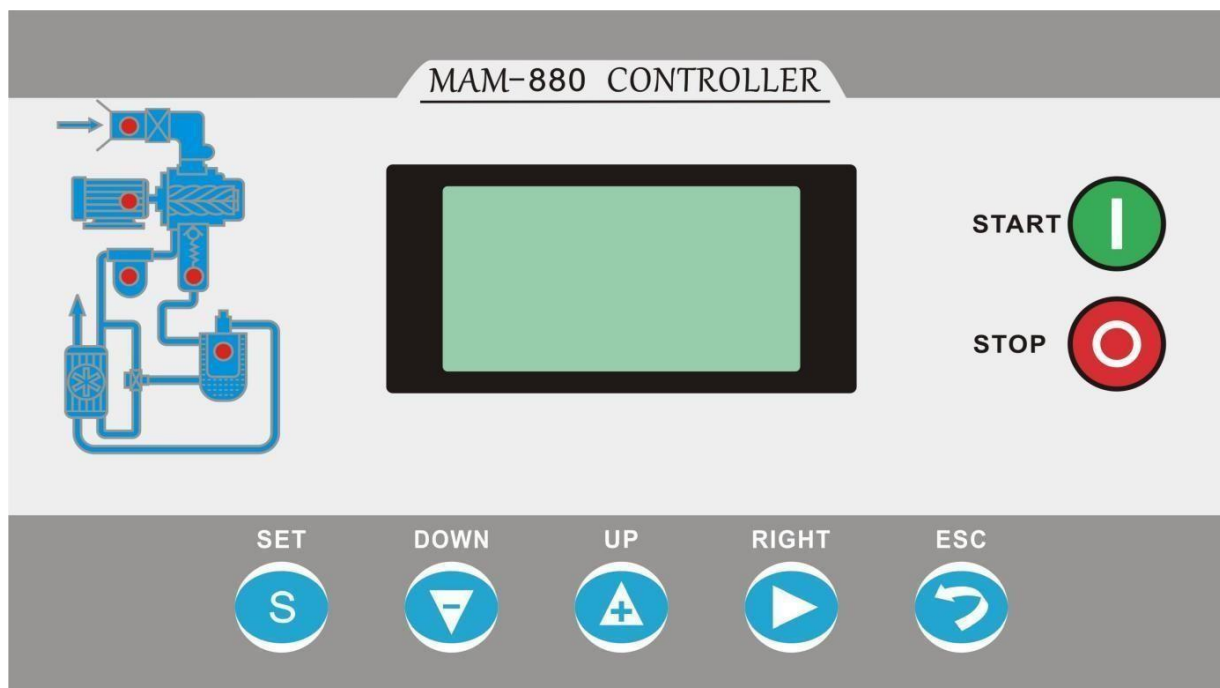

Picture 6.1

- I** — **Start button:** When the air compressor is in the standby state, press this button to run the air compressor; when the linkage control function is set correctly, if the air compressor is No. 1 and set as the host, press the start button to start the air compressor and simultaneously Start the linkage control function.
- O** — **Stop button:** When the air compressor is running, press this button to stop the air compressor; when the linkage control function is set correctly, if the air compressor is No. 1 and set as the host, press the stop button to stop the air compressor and simultaneously stop the linkage control function; When the equipment is in the stop state, long press the stop button to switch to the software version display interface.
- S** — **Load, unload button/ confirm button:** When the air compressor is running, this button is used as the load and unload button to control the loading or unloading operation of the air compressor; in the data setting mode, after modifying the data, press this button to confirm the data input; input After the password, press this button to confirm the password input and verify whether

the password is correct.



**Down button/Decrease button:** When viewing parameters, press this button to move the scroll bar down; when modifying data, press this button to decrease the current flashing position data.



**Up button/Increment button:** When viewing parameters, press this button to move up the scroll bar; when modifying data, press this button to increase the current flashing position data.



**Right button/Enter button:** When modifying data, the button is used as a shift button to move the flashing cursor to the next data bit; press this button when selecting a menu to enter the next level of the current menu, if the current menu does not have a next level Menu, enter the setting mode of the current menu, and a blinking cursor appears on the current menu data.



**ESC button/Reset button:** In the setting mode, press this button to exit the setting mode; in the parameter view mode, press this button to return to the previous menu; when a fault stops, long press this button to reset the fault.

## 2、Indicator Light Description

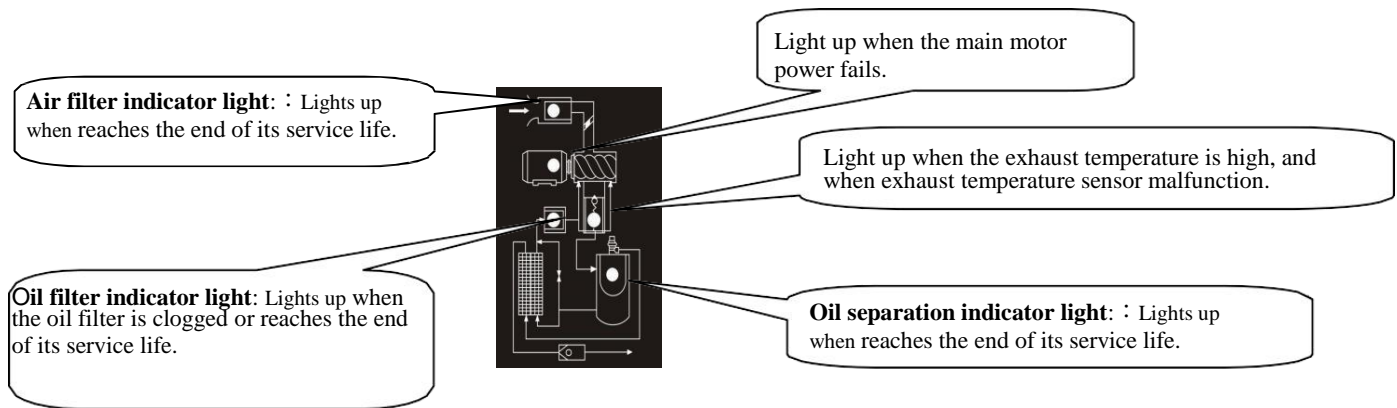

**Power supply:** The light is on after the controller is powered on.

**Running:** The running light is on when the air compressor motor is running.

**Fault:** The fault light flashes when the service life is reached; the fault light is always on when the fault stops, and the fault light goes out after the fault is cleared.

## 3、Status Display and Operation

After power on, the display interface is as follows:

Welcome to use  
screw compressor

After 5 seconds, the main interface is displayed as follows:

Exhaust temperature: 78°C  
Air supply pressure: 0.53MPa  
Device stopped: 0  
C16: Remotely

Press the shift button to enter the menu selection interface as follows :

Operating parameters  
User parameters  
Manufacturer parameters  
Adjustment parameters

#### 4、 Operating Parameters and Menu

Press the down button to move the black scroll bar to the "Operation Parameters" menu, and press the right button to switch to the next menu:

Current of motor and fan  
Total running time  
Running time  
Maintenance parameters

Historical fault  
Factory date, number field failure  
Communication status

Move the scroll bar to the corresponding menu item and press the enter button to view specific parameters, such as viewing "Current of motor and fan" Move the scroll bar to the "Current of motor

and fan" menu item, press the enter button to switch to the main and fan current value interface.

motor	fan
(A	(A
A 50.1	2.1
B 50.1	2.1
C 50.1	2.1

Press the ESC button to return to the previous menu or main interface. If you stop operating on an interface, it will automatically return to the main interface after 60 seconds.

### 5、View and modify user parameters

In the first level menu, press the up button or down button to move the black scroll bar to the "User Parameters" menu, and press the enter button to switch to the menu as follows:

ressure and temperature preset
Start-stop delay preset
Operation mode preset
Linkage parameter preset

Maintenance parameter reset
Maximum use time preset
Language selection: Chinese/English
user password : ****

Move the cursor to "pressure, temperature preset", then press the enter button to switch to:

Loading pressure: 00.62 MPa
Unloading pressure: 00.78MPa
Fan start temperature: 0080°C
Fan stop temperature: 0075°C

Move the cursor to the loading pressure menu, and then press the enter button to switch to the following interface to request the user password.

Enter password
* * * *

After displaying this interface, a flashing bit appears. Press the increment button or the decrease button to modify the current flashing position data, which is equal to the first data of the password. Press the right button to move the flashing cursor to the next data bit to modify the current flashing data. The second data equal to the password, modify the third and fourth data according to the above method, and finally press the enter button to confirm the input. After the system verifies that the password is correct, it will switch to the following interface:

There is a "\*" prompt in the upper right corner, indicating that the system has passed the password verification.

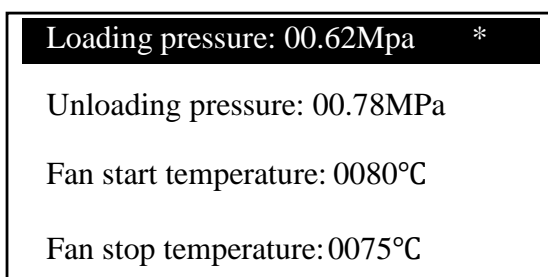

In the interface shown above, press right button, the first data bit of the loaded pressure starts to flash, the user can press increment button or decrease button to modify the current flashing bit data to be equal to the target value, press right button, the movement flashes Move the cursor to the next data bit, continue to modify the data to be equal to the target value according to the above method. After modifying all the data bits, press the enter button to save the user setting data. After the parameter is set successfully, the controller buzzer emits a short beep.

## 6、 User parameter table and function

First menu	Secondary menu	Set initial value	Function
Pressure and temperature preset	Loading pressure	**.**MPa	Load the pressure value and set it to automatic operation. After power-on, when the pressure is lower than the value set here, if the air compressor is in unloading operation, the controller controls the air pressure loading operation. If the air compressor is in idle shutdown, the controller Control the air compressor to start.
	Unloading pressure	**.**MPa	After start up, when the pressure is greater than the value set here, the controller controls the unloading operation of the air compressor.
	Fan start temperature	0080°C	When the exhaust temperature is higher than the value set here, start the fan to run.

	Fan stop temperature	0070°C	When the exhaust temperature is lower than the value set here, stop the fan operation.
Start-stop delay preset	Motor Delay	0008 second	Set the starting time of the motor. The motor starts timing. During this time, overload is not protected and the motor start-up impulse current is avoided.
	Fan Delay	0006 second	Set the starting time of the fan. The fan starts timing. During this time, overload is not protected and the motor start-up impulse current is avoided.
	Star angle delay	0006 second	Star angle step-down start delay time
	Load Delay	0002 second	After running, delay loading time
	No-load Delay	0600 second	The continuous running time of an empty vehicle, after which the air compressor will be switched to an empty standstill.
	Stop Delay	0010 second	When stopping, the air compressor will switch to no-load operation, and stop after the idle running delay for this time.
	Start delay	0100 second	After shutdown, empty vehicle shutdown for too long, or failure shutdown, the air compressor can be restarted after the time set here is delayed.
Operation method preset	Start-stop method	Local / remote	When set to local, the remote switch cannot start or stop the air compressor, when set to remote, both the remote switch and the local switch can start or stop the air compressor.
	Loading method	automatic / manual	When set to manual state, after the air compressor is turned on, loading and unloading need to be operated manually; when set to automatic, the air compressor automatically loads and unloads according to the pressure after turning on.
	Communication method	Prohibited / Computer / Linkage	When set to prohibit, communication does not work When set as a computer, as a slave, it communicates with external devices according to the MODBUS protocol. When set to linkage, multiple air compressors can be networked and run.
	Communication code	0001	When used for linkage or communicating with the host computer, set the communication address. The allowable setting range is 0-16 during linkage, and the allowable setting range is 0-99 when communicating with the host computer.
Linkage parameter preset	Linkage status	Master / slave	Multi-machine linkage operation as "master" or "slave" The host controls the start, stop, loading and unloading of the slave according to the air supply pressure.
	Rotation time	0099 Hours	During joint control, set the machine to work within the allowable pressure range Rotate after setting time here
	Number of linkages	0000	When the joint control is running, the number of air compressors in the joint control network.
	Lower limit of	**.**MPa	When the joint control is running, when the host pressure is lower than the pressure set here, find a machine from the joint control network to load or start

	pressure		
	Upper limit of joint pressure	**.**MPa	When the joint control is running, when the host pressure is higher than the pressure set here, find a machine from the joint control network to unload or shut down
	Linkage delay	0050 second	When the joint control is running, the waiting time for the host to send the control command twice continuously.
Maintenance parameter reset	Oil filter	0000 Hours	The accumulated use time of the oil filter, after replacing the new oil filter, reset it here.
	Oil separator	0000 Hours	The accumulated use time of the oil separator, after replacing the new oil separator, reset it here.
	Air filter	0000 Hours	The cumulative use time of the air filter is reset here after replacing the new air filter.
	lubricating oil	0000 Hours	Accumulated use time of lubricating oil, after replacing lubricating oil, reset it here.
	grease	0000 Hours	The accumulative use time of the grease is cleared here after replacing the grease.
	Belt	0000 Hours	The accumulative use time of the belt, after replacing a new belt, reset it here.
	Oil filter	**** Hours	When the accumulative use time of the oil filter exceeds the value set here, an early warning prompt; when set to "0000", the early warning of the use time of the oil filter does not work
	Oil separator	**** Hours	When the cumulative use time of the oil separator exceeds the value set here, an early warning will be given; when it is set to "0000", the early warning of the use time of the oil separator will not work.



# 7 Basic Operation and Parameter Setting of Variable Speed Controller

## (1) Basic operation

### 1、Button Description



Picture 7.1

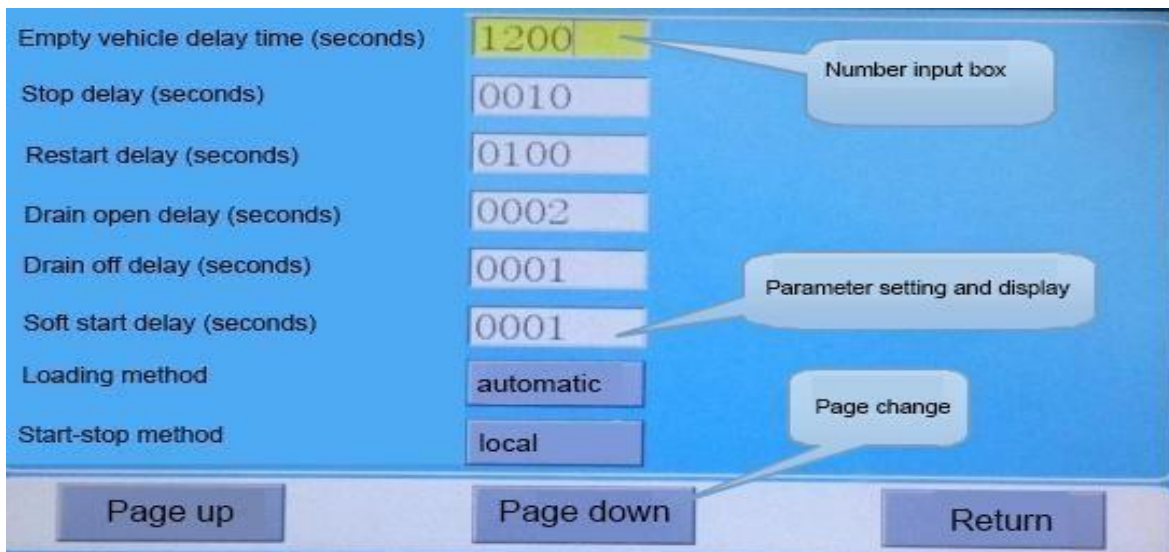

Picture 7.2



---**Start button:** When the air compressor is in standby state, press this button to start the air compressor operation; when the communication mode is set to linkage, and the communication address is 1, press this button to start the air compressor operation and at the same time start the linkage control function.



---**Stop button:** When the air compressor is running, press this button to stop the air compressor; when the communication mode is set to linkage, and the communication address is 1, press the stop button to stop the air compressor, and stop the linkage control function at the same time, and the host will no longer send Command to the slave.



---**Confirm button, load/unload button:** When the air compressor is running, this button is used as a loading and unloading button; When the input focus of the display interface is on the number input box and the input box is in edit mode, press this button to exit the edit mode and save the user modified data; When the input focus of the display interface is on the page change button, press this button to execute the corresponding function of the button.



---**Back button/Reset button:** When the fault stops, press this button for 5 seconds to reset the fault; In the setting mode, press this button to exit the setting mode and return to the viewing mode; In parameter view mode, press this button to return to the previous page.



--- **Left button:** When the focus of the display interface is on the number input box and is in the data viewing mode, press this button to enter the data editing mode, and the lowest bit of the data starts to flash. When the focus of the display interface is on the number input box and is in the data editing mode, press this button to move the editing bit to the previous digit of the current data. When the focus of the display interface is on the parameter setting and display button, press this button to modify the current parameter and save it. When the focus of the display interface is on the page change button, press this button to move the current focus to the next button.



--- **Right button / Enter button:** When the focus of the display interface is on the number input box and is in the data viewing mode, press this button to enter the data editing mode, and the highest bit of the data starts to flash; When the focus of the display interface is on the number input box and in the data editing mode, press this button to move the editing bit to the next digit of the current data; When the focus of the display interface is on the parameter setting and display button, press this button to modify the current parameter and save it; When the input focus of the display interface is on the page change button, press this button to move the current focus to the next button.



--- **Down button/decrement button:** When the current focus component of the display interface is in the data viewing mode, press this button to move the input focus to the next component. When the input focus of the display interface is on the number input box and in the data editing mode, press this button to decrease the current bit data. When the current interface is the operating parameter display interface, press this button to switch to the next page of operating parameter interface.



--- **Up button/Increment button:** When the current focus component of the display interface is in the data viewing mode, press this button to move the input focus to the previous component. When the focus of the display interface is on the number input box and is in the data editing mode, press this button to increase the current bit data. When the current interface is the operating parameter display interface, press this button to switch to the previous page of operating parameter interface.

## 2、Indicator light description

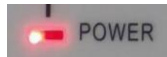

---**Power:** The light is on after the controller is powered on.

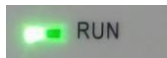

---**Run:** The running light is on when the air compressor motor is running.

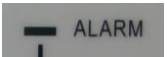

---**Alarm:** The fault light flashes when the service life is reached; the fault light is always on when the fault stops, and the fault light goes out after the fault is cleared.

## 3、Status display and operation

After the screen is powered on, the controller Logo “MAM-6080” will be displayed. After a period of delay, the display interface is as follows.



After a delay of 5 seconds, the display operating parameter interface is as follows :

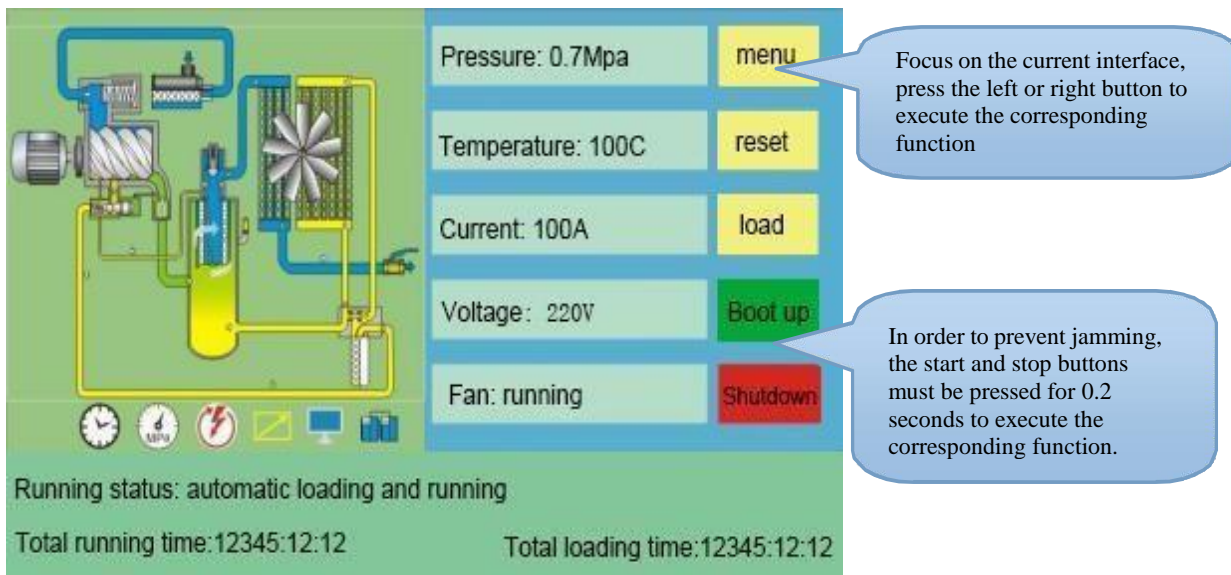

This icon indicates that the timing start-stop function is on.



This icon indicates that the timing pressure segment function is on.



This icon indicates that the power-off restart function is enabled.



This icon indicates that the remote function is on.



This icon indicates that the computer monitoring function is on.



This icon indicates that the joint control function is on.

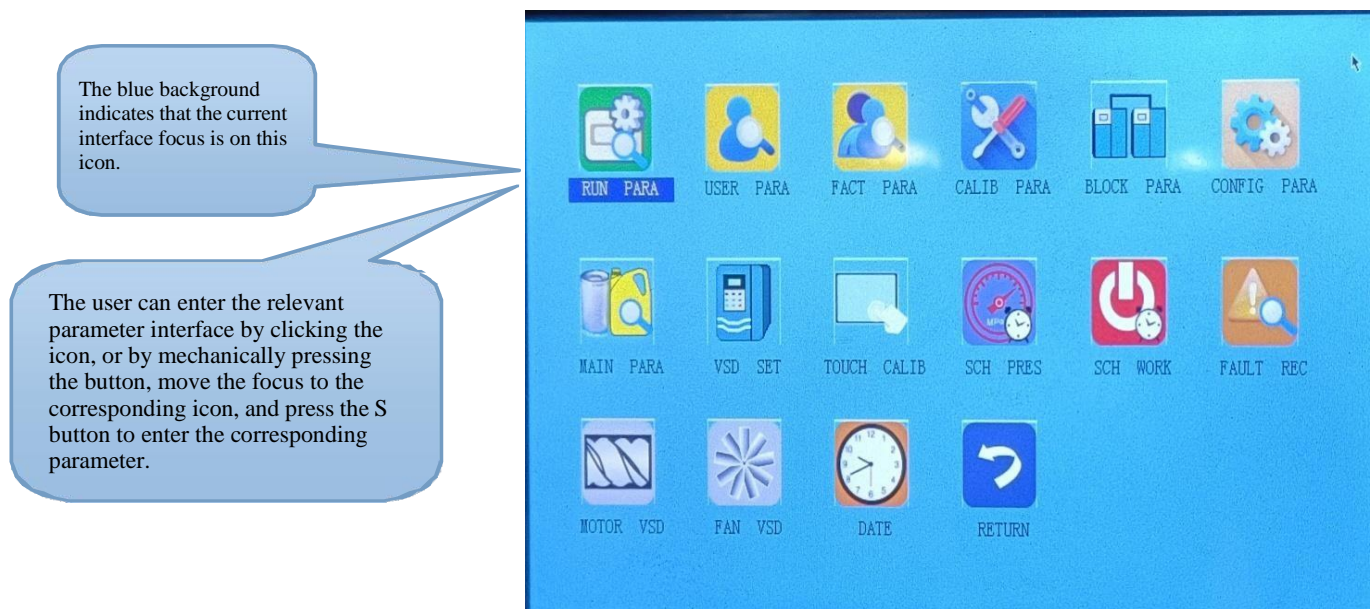

The user enters the following menu selection interface by clicking the “menu” button on the display interface, or pressing “>”, and the user enters the corresponding parameter viewing and setting interface through this interface.



#### 4、 Operating Parameters and Menu

Click "Operation Parameters" to view the related data and settings of the following operating parameters:

Menu	Set initial value	Function
Oil filter use time	0020H	Cumulative used time of oil filter
Oil separator use time	0020H	Accumulated used time of oil separator
Air filter use time	0020H	Air filter cumulative used time
Lubricant use time	0020H	Cumulative used time of lubricating oil
Grease use time	0020H	Accumulative grease used time
Host current	A : 000.0A B : 000.0AC : 000.0A	Display host current
Fan current	A : 000.0AB : 000.0A C : 000.0A	Display fan current
Running time	0000 : 00 : 00	The running time of the air compressor
This load time	0000 : 00 : 00	The load time of the air compressor

<p>Input state</p>	<p>1 2 3 4 5 6 7 8 9 10</p>  <p>1: Corresponding to the No. 5 switch input status;                  2: Corresponding to No. 6 switch input state;                  3: Corresponding to the No. 7 switch input state;                  4: Corresponding to the No. 8 switch input state;                  5: Corresponding to No. 9 switch input state;                  6: Corresponding to the No. 10 switch input state;</p> <p>When the terminal is closed, the color of the circle in the input port state is Chinese red, when the terminal is disconnected, the color of the circle in the input port state is light red</p>	
<p>Output state</p>	<p>1 2 3 4 5 6 7 8 9 10</p>  <p>1: Correspond to the No. 17 terminal relay output;                  2: Corresponding to the 16th terminal relay output;                  3: Corresponding to the relay output of terminal 15;                  4: Corresponding to the relay output of terminal 14;                  5: Corresponding to the 13th terminal relay output;                  6: Corresponding to terminal 12 relay output</p> <p>When the terminal is closed, the color of the circle in the output port state is China red, when the terminal is disconnected, the color of the circle in the output port state is light red</p>	
<p>Host speed</p>	<p>0000 RPM</p>	<p>Display the calculated real-time speed of the host according to the read frequency of the host</p>
<p>Host output frequency</p>	<p>000.0 Hz</p>	<p>Display the output frequency of the current host inverter</p>
<p>Host output current</p>	<p>000.0 A</p>	<p>Display the current output current of the host inverter.</p>
<p>Host output voltage</p>	<p>000.0 V</p>	<p>Display the current output voltage of the host inverter.</p>
<p>Host output power</p>	<p>000.0 Kw</p>	<p>Display the real-time output power of the current host inverter.</p>
<p>The host uses electricity this time</p>	<p>0000000.0Kw.H</p>	<p>The display controller accumulates the current running power consumption based on the real-time power output by the host inverter.</p>
<p>Cumulative power consumption of the host</p>	<p>0000000.0Kw.H</p>	<p>According to the real-time power output by the host inverter, the display controller accumulates the accumulated running power consumption.</p>
<p>Host status word</p>	<p>0000</p>	<p>The controller will display the running status register value read from the host inverter to the host status word display area.</p>
<p>The host uses electricity this time</p>	<p>0000000.0Kw.H</p>	<p>The display controller accumulates the current running power consumption based on the real-time power output by the host inverter.</p>

Cumulative power consumption of the host	0000000.0Kw.H	According to the real-time power output by the host inverter, the display controller accumulates the accumulated running power consumption.
Host status word	0000	The controller will display the running status register value read from the host inverter to the host status word display area.
Fault word	0000	The controller will display the fault status register value read from the host inverter to the fault word display area.
Write frequency	000.0	The controller will display the host frequency value obtained by PID calculation here.
Fan speed	0000 RPM	According to the read fan frequency, display the calculated real-time speed of the fan
Fan output frequency	000.0 Hz	Display the current output frequency of the fan inverter
Fan output current	000.0 A	Display the current output current of the fan inverter.
Fan output voltage	000.0 V	Display the current output voltage of the fan inverter.
Fan output power	000.0 Kw	Display the real-time output power of the current fan inverter.
The fan uses electricity this time	000000.00Kw.H	According to the real-time power output by the fan inverter, the display controller accumulates the current running power consumption.
Cumulative power consumption of fans	000000.00Kw.H	The display controller accumulates the accumulated running power consumption according to the real-time power output by the fan inverter.
Fan status word	0000	The controller displays the running status register value read from the fan inverter to the fan status word display area.
Fault word	0000	The controller will display the fault status register value read from the fan inverter to the fault word display area.
Write frequency	000.0	The controller will display the frequency value obtained through PID operation in the writing frequency value display area.

### 5、 User parameters

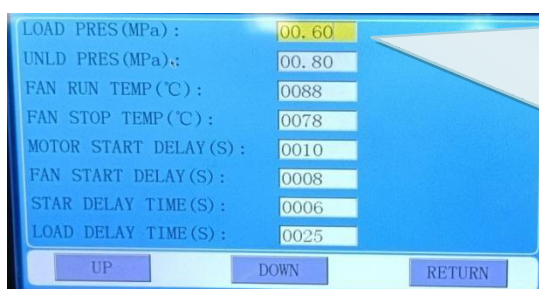

When the input focus falls on the

Touch operation: (Focus background color is yellow)

1. The input focus of the current form is here. If the password has been verified, click directly, and the numeric keypad will pop up to modify the parameters;
2. If the password is not verified, click it to pop up the password verification

The main functions and functions are shown in the following table:

Menu	Set initial value	Function
Air supply loading pressure (MPa)	00.65	1. The loading mode is set to automatic. When the air compressor is in automatic unloading operation, the pressure lower than this value will control the air compressor to automatically load. 2. When the air compressor is idle for a long time, the pressure is lower than this value, and the operating conditions are met, the controller automatically starts the air compressor to run.
Unloading pressure of air supply (MPa)	00.80	1. The pressure is higher than this value, and it is in the loading operation state, controlling the unloading operation of the air compressor. 2. The setting value of "air supply loading pressure" cannot be greater than this value, and "air supply unloading pressure" is limited by the "unloading pressure high limit" in the factory parameters.
Fan start temperature (°C)	0080	When the air compressor is running, when the exhaust temperature is higher than the value set here, the fan is controlled to run.
Fan stop temperature (°C)	0070	When the air compressor is running, when the exhaust temperature is lower than the value set here, the fan will stop running.
Host start delay (seconds)	0008	Set the starting time of the main motor, and start timing when the main motor starts. During this time, the main motor is not protected against current overload.
Fan start delay (seconds)	0003	Set the start time of the fan, and start timing when the fan starts. During this time, the fan will not be protected against current overload.
Star angle delay (seconds)	0006	The start delay time of the host star angle step-down voltage.
Loading delay (seconds)	0002	After the host computer is running, the loading time is delayed.
Empty vehicle delay time (seconds)	0600	The longest continuous no-load running time allowed by the air compressor, after this time, it will automatically stop running and enter the idle state for too long.
Stop delay (seconds)	0010	During normal shutdown, the air compressor immediately runs at no-load, and stops after the set time of no-load operation.
Restart delay (seconds)	0100	After a normal shutdown, an empty vehicle shutdown for too long or a fault shutdown, the time set here needs to be delayed
Drain open delay (seconds):	0002	Only then can the air compressor be restarted.
Drain off delay time (minutes):	0060	During automatic drainage control, continuous drainage time (standby)
Soft start delay (seconds):	0006	During automatic drainage control, drainage interval time (standby)
Loading method:	automatic / manual	Manual mode: automatic unloading when the pressure is higher than the "unloading pressure"; other conditions are controlled by the loading and unloading buttons; Automatic mode: The controller automatically controls the loading and unloading of the air compressor according to the pressure and the set loading and unloading pressure.
Start-stop method:	Local/remote	Local mode: The remote start terminal has no function. Remote mode: The remote start terminal function is valid.  Note: When a hardware input terminal is set to "remote start enable", the start-stop mode is determined by the hardware state. When the terminal is closed, it is remote, when it is open, it is local. The setting here has no effect.
Operation mode:	Power frequency / soft start / main fan frequency conversion / fan frequency conversion / host frequency	Users can choose air compressor models according to their needs. According to the selected model, refer to the corresponding electrical diagram for wiring.



	conversion	
mailing address:	0001	When the communication method is a computer or linkage, the communication address of the controller.
Backlight brightness adjustment:	0001	Adjust the backlight brightness, the higher the value, the stronger the brightness. (1~4 levels of brightness adjustable)
way of communication:	Prohibited / Linkage / Computer	When set to prohibit, communication does not work; When set to communication, as a slave, it communicates with external devices according to MODBUS RTU protocol, baud rate: 9600; data format: 8N1; parity: even parity When set to linkage, multiple air compressors can be networked and run.
Pressure unit:	MPa/PSI/BAR	If set to MPa, the parameter unit related to pressure is displayed as MPa. If set to PSI, the parameter unit related to pressure is displayed as PSI. (spare) For example, when it is set to BAR, the parameter unit related to pressure is displayed as BAR. (spare)
Temperature unit:	°C/°F	If set to °C, the parameter unit related to temperature is displayed as °C. If set to °F, the parameter unit related to temperature is displayed as °F. (spare)
language selection:	Chinese / English	When set to Chinese, the display interface is displayed in Chinese; When set to English, the display interface is displayed in English; (spare)
user password:	****	Modifiable user password; can be reset with old user password or factory password.

## 6、 Calibration parameters

The calibration parameters are used to set the controller related data. The user needs to verify the calibration password before viewing or modifying the calibration parameters. The main functions and functions are shown in the following table:

Menu	Set initial value	Function
Host A phase coefficient	1.000	Used to calibrate the current. Current coefficient setting range: 0.800-2.000. Current value = sampling value × current coefficient
Host B phase coefficient	1.000	
Fan A phase coefficient	1.000	
Fan B phase coefficient	1.000	
Fan C phase coefficient	1.000	
Temperature 1 factor	1.000	Used to calibrate the exhaust temperature. Temperature coefficient setting range: 0.800-2.000 temperature value = detection temperature value × temperature coefficient
Temperature 2 factor	1.000	Note: For MAM6080 controller, this parameter is reserved.

Temperature 3 factor	1.000	
Temperature 4 factor	1.000	
Temperature 5 factor	1.000	
Temperature 6 factor	1.000	
Pressure 1 factor	1.000	Used to calibratetheairsupplypressurevalue. Pressurecoefficientsettingrange: 0.800-2.000. Pressure value = detection pressure value × pressure coefficient
Pressure 2 factor	1.000	Note: For MAM6080 controller, this parameter is reserved.
Voltage coefficient	1.000	Usedto calibratethevoltage detectionvalue. Voltagecoefficientsettingrange:0.800-2.000. Voltage value = detection voltage value × voltage coefficient
PWM1 coefficient	1.000	Note: For MAM6080 controller, this parameter is reserved.
PWM2 coefficient	1.000	
Temperature 1 zero	0002	Used to adjust the temperature zero point of the controller. When the controller temperature sensor wiring terminal is connected to the resistance corresponding to -20°C, adjust this value to adjust the temperature to -20°C. Temperature calibration.
Temperature 2 zero	0002	Note: For MAM6080 controller, this parameter is reserved.
Temperature 3 zero	0002	
Temperature 4 zero	0002	
Temperature 5 zero	0002	
Temperature 6 zero	0002	
Pressure 1 zero	0002	
Pressure 2 zero	0002	When the pressure 2 value is less than the set value, the displayed pressure value is 0.00, which is used to prevent the air supply pressure sensor from drifting up. (spare)
PWM1 zero	0002	(spare)
PMW2 zero	0002	(spare)
Phase sequence protection value (V)	000.9	When the voltage value detected by the three-phase phase sequence detection circuit is lower than the value set here, the phase sequence error is reported. When this value is set to 0, the phase sequence protection function is disabled.
Lack of sequence protection value (V)	000.0	When the detected open-phase voltage value is lower than the value set here, a phase sequence error is reported. When this value is set to 0, the phase sequence open-phase protection function is prohibited.
Host current ratio	020	Note: For MAM6080 controller, this parameter is reserved.
Fan current ratio	001	Host rated current/5

## 7、 Joint control parameters

The joint control parameters are used to set joint control related functions. Before users modify the joint

control parameters, they need to verify the joint control parameter password. The main functions and functions are shown in the following table:

Menu	Set initial value	Function
Number of linkages:	0002	When the joint control is running, the number of air compressors in the joint control network.
Linkage loading pressure (MPa)	00.63	When the joint control is running, when the host pressure is lower than the pressure set here, find a machine from the joint control network to load or start
Linkage unloading pressure (MPa)	00.78	When the joint control is running, when the host pressure is higher than the pressure set here, find a machine from the joint control network to unload or shut down.
Linkage delay time (seconds):	0020	When the joint control is running, the waiting time for the host to send the control command twice continuously.
Rotation time (minutes):	0060	The pressure of the host is between the pressures of "linkage loading" and "linkage unloading". There are machines running in the network and some machines are shutting down. After this situation lasts for this set time, the main machine will send a shutdown instruction to the running machine, and at the same time, the machine will be stopped. The machine sends a boot command.
Linkage network:	Fixed speed-Fixed speed Fixed speed-Variable Speed Variable Speed-Variable Speed	Fixed speed-Fixed speed : Used for joint control of Fixed Speed air compressor and Fixed Speed air compressor; Fixed speed-Variable Speed : Used for joint control of Fixed Speed air compressor and variable speed air compressor; Variable Speed-Variable Speed : Used for joint control of Variable Speed air compressor and Variable Speed air compressor.

## 8、Hardware parameters

The hardware parameters are used to set the functions of No. 5-10 multi-function terminals. The main functions and functions are shown in the following table:

Menu	Set initial value	Function
Function of No. 10 terminal:	Emergency stop	No function/emergency stop/remote open/remote close/remote jog/remote hold/water shortage normally closed/remote loading/remote start enable/remote
Function of terminal 9:	Water shortage	loading/unloading open/cylinder temperature high and normally closed/coil temperature high and normally closed/ High bearing temperature normally closed/electrical fault normally closed/motor overload
Function of No. 8 terminal:	Oil filter	Normally closed/fan overload normally closed/oil filter blocked normally closed/oil
Function of No. 7 terminal:	Oil	filter blocked normally open/oil separator blocked normally closed/oil separator blocked normally open/air filter blocked normally closed/air filter blocked Normally open/air side fault normally closed/refrigerator and dryer fault normally closed/host inverter fault
Function of Terminal 6:	air filter	Normally open/main unit inverter fault normally closed/fan inverter fault normally open/fan inverter fault normally closed
Function of No. 5 terminal:	Remote switch	Note: The user can set the switch input as the required function according to the needs.

## 9、 Consumable parameters

The Consumable parameters are used to set the consumable time. The user needs to verify the password of the consumable before viewing or modifying the parameters of the consumables. The main functions and functions are shown in the following table:

Menu	Set initial value	Function
Oil filter use time (hours)	0000	The accumulated used time of the oil filter, after replacing the new oil filter, manually clear it.
Oil separator use time (hours)	0000	The accumulated used time of the oil separator should be cleared manually after replacing the new oil separator.
Air filter use time (hours)	0000	The air filter has accumulated used time. After replacing the new air filter, reset it manually.
Lubricating oil use time (hours)	0000	The accumulated used time of lubricating oil, after replacing lubricating oil, clear it manually.
Grease use time (hours)	0000	The accumulated used time of the grease, after replacing the grease, clear it manually.
Maximum use of oil filter (hours)	2000	1. When the cumulative use time of the oil filter exceeds the value set here, the controller will warn;
Maximum use of oil separator (hours)	2000	2. When set to "0000", the oil filter warning function is prohibited
Maximum use of air filter (hours)	2000	1. When the cumulative use time of the oil separator exceeds the value set here, the controller will warn;
Maximum use of lubricating oil (hours)	2000	2. When set to "0000", the oil separator warning function is prohibited
Maximum use of grease (hours)	2000	1. When the cumulative use time of the air filter exceeds the value set here, the controller will warn;

## 10、 Screen calibration

Screen calibration is used to calibrate the accuracy of screen operation. The user needs to verify the screen calibration password before entering the screen calibration. After entering the screen calibration interface, use your fingertips or other pointed tools to click A, B, C, D, E in turn. If the desired effect is achieved, click OK, and the controller will restart to save the settings; if the desired effect is not achieved, click Recalibrate and calibrate again according to the previous method until the desired effect is achieved.

## 11、 Timing pressure

The timing pressure is used to set the timing pressure value. Before users modify the timing pressure parameters, they need to verify the timing pressure password. The main functions and functions are shown in the following table :

Menu	Set initial value	Function
Loading pressure (MPa)	00.65	When the time is between "pressure opening time" and "pressure ending time", the pressure is lower than this set value to load.
Unloading pressure (MPa)	00.80	When the time is between "pressure opening time" and "pressure ending time", the pressure is higher than this set value to unload.
Variable Speed working pressure (MPa)	00.70	When the time is between "pressure opening time" and "pressure ending time", set the air supply pressure of the variable frequency air compressor during stable operation. When the pressure fluctuates near this pressure, the controller adjusts the operating frequency of the frequency converter, thereby Make the air supply pressure close to the value set here. (This parameter only works when the model is set to host frequency conversion or main fan frequency conversion)
Stress start time	00:00	When this time is not "00:00", the above setting function is activated, otherwise it is prohibited.
Stress end time	00:00	When this time is not "00:00", the pressure end function is activated when the above setting is set, otherwise it is prohibited.

## 12、 Timed start and stop

Timing start and stop is used to set one week of timing on and off time, four sections of timing on and off time can be set every day. The user needs to verify the timing start and stop password before modifying the timing start and stop time. When the data is set to 00:00, the corresponding function does not work.

## 13、 Historical fault

Record historical fault information to facilitate users to find out the cause of the fault and eliminate peripheral faults. The controller can record up to 100 historical faults.

## 14、 Host frequency conversion

Host frequency conversion is used to set the host frequency conversion parameters. The user needs to verify the frequency conversion password of the host before modifying the frequency conversion parameters of the host. The main functions and functions are shown in the following table :

Menu	Set initial value	Function
Host frequency conversion pressure (MPa)	00.70	Set the air supply pressure when the variable frequency air compressor is running stably. When the pressure fluctuates near this pressure, the controller adjusts the frequency of the inverter to make the air supply pressure close to the value set here. (This parameter only works when the model is set to host frequency conversion or main fan frequency conversion)
Host ascent rate	1000	During PID adjustment, it is used to limit the increment of each PID operation result. To prevent excessive increase in frequency during the operation of the air compressor, resulting in excessive increase in motor speed.
Host drop rate	1000	During PID adjustment, it is used to limit the decrement of each PID operation result. To prevent excessive reduction in frequency when the air compressor is running, causing the motor speed to drop too fast.

Main engine power (KW)	022.0	Set the rated power of the motor, used to calculate the actual power of the motor when the motor is working with frequency conversion (this parameter only works when the model is set to the host frequency conversion or the main fan frequency conversion)
Main engine speed (RPM)	1500	Set the rotation speed when the motor is working at the highest frequency, which is used to calculate the actual rotation speed of the motor when the motor is working in variable frequency. (This parameter only works when the model is set to host frequency conversion or main fan frequency conversion)
Initial value of host integral	0080	When the detection pressure <(set working pressure-integral range), the integral is calculated with the set value;
Host integral range (Mpa)	00.05	When the detection pressure>(set working pressure + integral range), the integral is calculated based on the set value
Host proportional gain	0025	In variable frequency operation, when (set working pressure-integral range) <detection pressure <(set working pressure + integral range), the integral gain will work
Host integral gain	0030	Track and set the working pressure speed, the larger the value, the faster the tracking, easy to oscillate; the smaller the value, the slower the tracking, the slower the adjustment.
Host differential gain	0000	Track the setting working pressure speed and determine the steady-state error, the larger the value, the faster the tracking, the smaller the steady-state error; the smaller the value, the slower the tracking, the larger the steady-state error.
Host frequency upper limit (HZ)	050.0HZ	The maximum operating frequency that the air compressor is allowed to output when loading
Host frequency lower limit (HZ)	030.0HZ	During the adjustment process, when the pressure exceeds the set working pressure but does not reach the unloading pressure, the minimum working frequency that is allowed to be output.
Host no-load frequency (HZ)	0025.0HZ	Allowable output operating frequency of air compressor when no load
Host inverter station number	0001	Set the station number of the host inverter. This value must be consistent with the communication station number of the inverter.
Host PID cycle (seconds)	000.8 秒	The controller performs a PID calculation at the interval set time to adjust the host speed.
Host inverter model	ATV61	The controller can store up to 10 different types of inverter communication addresses (for communication to read inverter parameters, the inverter needs to support MODBUS RTU protocol)
Host shutdown mode	Deceleration stop/free stop	<p>1. When the start mode of the main inverter is set to start and stop communication:</p> <p>Decelerating to stop: When the stop mode in the manufacturer's parameters is set to decelerate to stop, after the controller receives the stop command, the loading valve is disconnected, and the controller sends a deceleration to stop command to the inverter, and the inverter decelerates to stop according to the set deceleration time.</p> <p>Free stop: When the stop mode in the factory parameters is set to free stop, after the controller receives the stop command, the loading valve is disconnected, and the controller sends a frequency write command through the 485 communication port to control the frequency of the inverter to decrease until the stop delay Send a stop command to the inverter 1 second before the countdown is completed.</p> <p>2. When the start mode of the main inverter is set to terminal start and stop:</p> <p>Decelerating to stop: When the stop mode in the factory parameters is set to decelerate to stop, after the controller receives the stop command, the loading valve is disconnected, and the control host inverter running terminal is disconnected. The inverter decelerates to stop according to the set deceleration time.</p>

		Free stop: When the stop mode in the factory parameters is set to free stop, after the controller receives the stop command, the loading valve is opened, the control host inverter operation terminal remains closed, and the inverter frequency is controlled to decrease until the stop delay countdown is completed. Disconnect in 1 second.
Main inverter start mode	Communication start and stop/terminal start and stop	Communication start and stop: Start the inverter through RS485 communication. Terminal start and stop: start and stop the inverter through the switch value. note: 1: The controller setting parameters must be consistent with the inverter start-stop mode. 2: When the user needs to switch between the inverter and the inverter, terminal 12 is used as the control terminal of the inverter. The controller can only start and stop the inverter by communication.
Frequency of communication start	0006	After the controller sends the start command to the inverter, it is found that the inverter has not executed the running command, and the start command can be repeated at most the set times.
Frequency of communication stop inverter	0006	After the controller sends a stop command to the inverter, it is found that the inverter has not executed the stop command.
Frequency conversion host power Kw.H	0000000.0	Set the accumulative power consumption of the host in variable frequency operation
Delay of pre-opening the host inverter (S)	1.0	After pressing the start button, the set time is delayed and the start command is sent to the inverter.
Constant power pressure 1 (MPa)	0.60	When used for constant power operation, when the pressure is detected to be greater than or equal to the value set here, the output frequency is allowed to output up to the "constant power frequency 1" setting value.
Constant power pressure 2 (MPa)	0.70	When used for constant power operation, when the pressure is detected to be greater than or equal to the value set here, the output frequency is allowed to output up to the "constant power frequency 2" setting value.
Constant power pressure 3 (MPa)	0.80	When used for constant power operation, when the pressure is detected to be greater than or equal to the value set here, the output frequency is allowed to output up to the setting value of "constant power frequency 3".
Constant power pressure 4 (MPa)	0.90	When used for constant power operation, when the pressure is detected to be greater than or equal to the value set here, the output frequency is allowed to output up to the "constant power frequency 4" setting value.
Constant power pressure 5 (MPa)	1.00	When used for constant power operation, when the pressure is detected to be greater than or equal to the value set here, the output frequency is allowed to output up to the setting value of "constant power frequency 5".
Constant power pressure 6 (MPa)	1.10	When used for constant power operation, when the pressure is detected to be greater than or equal to the value set here, the maximum allowable output frequency is the "constant power frequency 6" setting value.
Constant power pressure 7 (MPa)	1.20	When used for constant power operation, when the pressure is detected to be greater than or equal to the value set here, the maximum allowable output frequency is the setting value of "constant power frequency 7".
Constant power frequency 1 (HZ)	180.0	
Constant power frequency 2 (HZ)	160.0	
Constant power frequency 3(HZ)	140.0	
Constant power frequency 4(HZ)	120.0	

Constant power frequency 5(HZ)	100.0	See note 1 after the table:
Constant power frequency 6(HZ)	80.0	
Constant power frequency 7(HZ)	60.0	

Note 1: In constant power control:

Constant power pressure 1<=constant power pressure 2<=constant power pressure 3<=constant power pressure 4<=constant power pressure 5<=constant power pressure 6<=constant power pressure 7

Note 2: Constant power frequency 1>=constant power frequency 2>=constant power frequency 3>=constant power frequency 4>=constant power frequency 5>=constant power frequency 6>=constant power frequency 7

Note 3: Assuming M>N, when the constant power pressure N is set to 00.00, the setting of the constant power pressure M and the corresponding constant power frequency M has no effect.

Note 4: When the user does not need to use the constant power function, the constant power pressure 1 can be set to 00.00MPa.

### 15、 Fan frequency conversion

Fan frequency conversion is used to set the fan frequency conversion parameters. The user needs to verify the fan frequency conversion password before modifying the fan frequency conversion parameters. The main functions and functions are shown in the following table:

Menu	Set initial value	Function
Fan frequency conversion temperature (°C)	0078°C	Set the exhaust temperature when the air compressor is running stably. When the exhaust temperature fluctuates near this value, the controller adjusts the fan inverter operating frequency so that the exhaust temperature is close to the value set here. (This parameter only works when the model is set to fan frequency conversion or the main fan frequency conversion)
Maximum frequency conversion temperature (°C)	0085°C	When the exhaust temperature is greater than or equal to this value, control the output frequency of the fan inverter, which is the upper limit of the frequency set in the manufacturer's parameters. (This parameter only works when the model is set to the fan frequency conversion or the main fan frequency conversion .)
Fan rising rate	1000	During PID adjustment, it is used to limit the increment of each PID operation result. Prevent the fan from increasing too much frequency during operation, causing the fan speed to increase too fast.
Fan descent rate	1000	During PID adjustment, it is used to limit the decrement of each PID operation result. Prevent air pressure
Rated fan power	001.5KW	When the machine is running, the frequency is reduced too much, causing the fan speed to drop too fast.
Fan rated speed	1500RPM	Set the corresponding speed when the fan is running at the highest frequency. When the motor works with variable frequency,
Frequency conversion fan start (°C)	0070°C	Calculate the actual speed of the motor. (This parameter only works when the model is set to fan frequency conversion or main fan frequency conversion)
Frequency conversion fan stop (°C)	0065°C	When the exhaust temperature is greater than this set value, the frequency conversion fan will start. (This parameter only works when the model is set to the fan frequency conversion)



		or the main fan frequency conversion)
Initial value of fan integral	0020	When the exhaust temperature is lower than this set value, the frequency conversion fan stops. (This parameter only works when the model is set to fan frequency conversion or main fan frequency conversion)
Fan integral range (°C)	0005°C	When the detection temperature <(set frequency conversion working temperature-integration range), the integral is calculated with the set value; when the detection temperature> (set frequency conversion working temperature + the integral range), the integral is calculated with the set value.
Fan proportional gain	0100	Tracking the setting speed of the working temperature, the larger the value, the faster the tracking, easy to oscillate; the smaller the value, the slower the tracking and the slower the adjustment.
Fan integral gain	0020	Track the setting speed of the operating temperature and determine the steady-state error. The larger the value, the faster the tracking and the smaller the steady-state error; the smaller the value, the slower the tracking and the larger the steady-state error.
Fan differential gain	0000	Generally not used, set to "0000".
Fan frequency upper limit (HZ)	050.0HZ	During the adjustment process, when the temperature exceeds the variable frequency operating temperature, the maximum operating frequency allowed to be output.
Lower limit of fan frequency (HZ)	010.0HZ	During the adjustment process, the temperature is lower than the minimum operating frequency that is allowed to output when the variable frequency operating temperature is set
Frequency conversion fan power factor	0.900	Calculate the power coefficient of the variable frequency fan and set the corresponding communication station number of the fan inverter.
Fan inverter station number	2	The controller performs a PID calculation at the interval set by the controller to adjust the fan speed.
Fan PID cycle (seconds)	001.5秒	Select the built-in inverter protocol.
Fan inverter model	ATV31	Set the start mode of the fan inverter
Fan inverter start mode	Communicationstartandstop /terminalstartandstop	Inverter fan electricity
Electricity for frequency conversion fan (Kw.H)	000000.0 0	Tracking the setting speed of the working temperature, the larger the value, the faster the tracking, easy to oscillate; the smaller the value, the slower the tracking and the slower the adjustment.

## 16、 Date and time

Used to view and set the internal time of the controller.

### (2) Controller function and technical parameters

1. Working environment: -20°C~+60°C; relative humidity: ≤98%;
2. Switch: 6-channel switch input (optional function), 6-channel relay switch output
3. Analog quantity: 1 PT100 temperature input. 2 groups of three-phase current input (with CT).
4. Phase sequence input voltage: three-phase 380V/220V.
5. The working voltage of the air compressor is too low and high protection.

6. Controller working power: AC16-28V, 15VA

7. Display range

Exhaust temperature:  $-50\sim 350^{\circ}\text{C}$ , accuracy:  $\pm 1^{\circ}\text{C}$ .

Running time:  $0\sim 999999$  Hours.

Current display range:  $0\sim 999.9\text{A}$ .

Pressure:  $0\sim 1.60\text{MPa}$ . Accuracy;  $0.01\text{Mpa}$ .

8. Phase sequence protection: When the air compressor is stopped and the phase sequence is detected reversed, the action time is less than 1 second.

9. Motor protection: The controller has phase loss, unbalance, and overload protection for the main motor, and overload protection for the fan.

Phase loss protection: When any one-phase current is missing phase, the action time is equal to the set time; when the phase loss protection time is set to greater than 20 seconds, the phase loss protection does not work.

Unbalance protection: the maximum current value minus the minimum current value, which is greater than or equal to the set value, multiplied by the minimum current value, and divided by 10, hour. Action time is 5 seconds.

Overload inverse time protection characteristics (time unit is second), see the table below. Multiplier =  $I_{\text{real}} / I_{\text{setting}}$ , when the motor running current is greater than or equal to 1.2 times to 3.0 times of the set current, the overload multiple and action time delay action in the following table.

10. Temperature protection: When the detected actual temperature is greater than the set temperature, the action time is less than 2s.

11. Output relay contact capacity: 250V, 5A; contact life is 500000 times.

12. The current display error is less than 1.0%.

13. Two RS485 communication interfaces. 1 channel is used for joint control or communication with computer. The other one communicates with the inverter to control the operation of the inverter and read the inverter operating parameters.

14. Remote start and stop the air compressor: When the start and stop mode is set to remote, the user can start or stop the air compressor through the remote terminal.

## 8 Warnings and Precautions

### 1、Machine power distribution

1. According to the power, voltage and frequency characteristics of the air compressor, select a matching power supply and a suitable power cord (if conditions permit, it should be equipped with cables with excellent performance such as high temperature resistance and anti-aging, so as to avoid the power cord and power supply causing air loss. Press failure).
2. The cross-sectional area of the power cord shall not be less than the data listed in Table 2.

Item	Motor power (KW)	Cross-sectional area <sup>2</sup> (mm)	Item	Motor power (KW)	Cross-sectional area <sup>2</sup> (mm)
10A	7.5	6	100A	75	50
15A	11	10	120A	90	70
20A	15	10	150A	110	95
25A	18.5	16	175A	132	95
30A	22	16	215A	160	120
40A	30	25	250A	185	150
50A	37	35	270A	200	185
60A	45	35	220A	220	185
75A	55	50	350A	250	185

3. According to the power and voltage of the air compressor, a full-time electrician should select the type and configure an appropriate air switch to protect the power and electrical system and ensure safety.



Picture 8.1 air switch

4. The air compressor must be grounded reliably to prevent leakage and static electricity from causing danger.
5. Large-displacement air compressors should consider using a separate set of power supply units, so as

not to affect the normal operation of other equipment, otherwise it is not conducive to the normal use of the air compressor (which will cause the screw machine protection device to operate).

## 2、Precautions

1. In order to prevent the air compressor from being damaged by bumps during storage and transportation, the transportation fastening screws have been locked before leaving the factory. The user must loosen the fasteners before use.
2. The commissioning of the new machine must be performed by commissioning personnel designated or approved by our company.
3. The operator must read, understand and follow the relevant operating procedures, precautions and maintenance specifications of the machinemanual.
4. Air compressors without air tanks must be equipped with air tanks before they can be used.
5. The air compressor can not be changed at will and set the rated working pressure to avoid damage to the motor due to overload.
6. The air compressor must work in an environment with good indoor ventilation and a temperature below 45 °C.
7. Terminals must be installed on the power access line to ensure that the terminal screws are securely fastened and will not loosen. The wires must be installed by a full-time electrician.

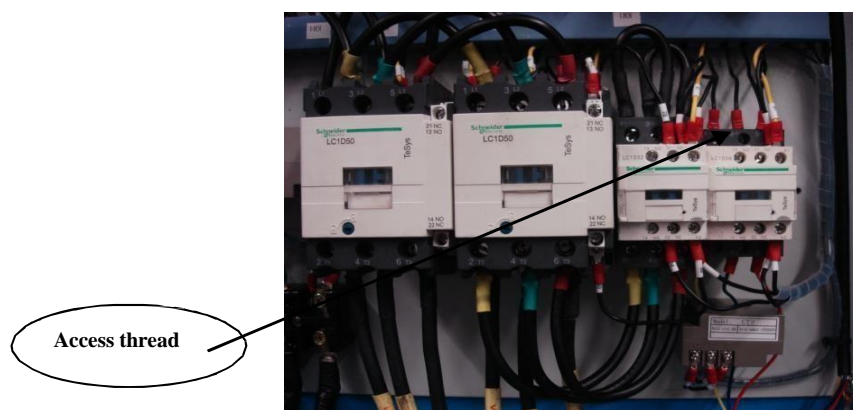

Picture 8.2 Thread terminal

8. It is strictly forbidden to operate the air compressor for a long time under a pressure lower than 0.4Mpa.
9. Keep the lubricating oil within the upper and lower limits of the oil standard. Use 46# special lubricating oil for screw compressors. It is strictly forbidden to mix two different brands of oil to avoid major accidents caused by coke accumulation in the pipeline system.
10. It is strictly forbidden to check and repair electrical appliances and circuits without cutting off the power supply.

11. It is strictly forbidden to inspect and repair the pressure volume and pressure pipeline without pressure relief.
12. Remove the water in the oil and gas cylinder in time.
13. The exhaust temperature should be between 70 and 105°C.
14. When maintaining and cleaning parts, do not use flammable, explosive and volatile cleaning agents, and use non-corrosive and safe solvents.
15. When the air compressor has a fault prompt, do not force it to start, find out the cause in time and deal with it accordingly.

## 9 Equipment Installation

### Installation site selection & cooling ventilation system

To be able to use the air compressor correctly, it is necessary to properly plan the installation site so that the air compressor can get a good environment during the use and maintenance process. A reasonable venue should have the following basic conditions.

1. The air compressor should be installed in a clean, dry, well-ventilated room, free of dust and harmful gases.
2. The working environment temperature is not higher than 45°C. The relative humidity of the surrounding atmosphere should be less than 80%.
3. The installation ground must be solid and level. Keep level.
4. If your planned site is an air compressor station, you should configure appropriate compressed air processing equipment, valves, pipes, and pressure vessels in accordance with relevant regulations.

In order to ensure that the air compressor has good heat dissipation conditions and maintenance space, the distance between the air compressor and the wall should not be less than 1 meter, and a space of more than 1.5 meters should be reserved at the top to prevent the exhaust hot air and the intake cold air from forming a wind bridge. Exhaust devices should also be configured for poorly ventilated computer rooms.

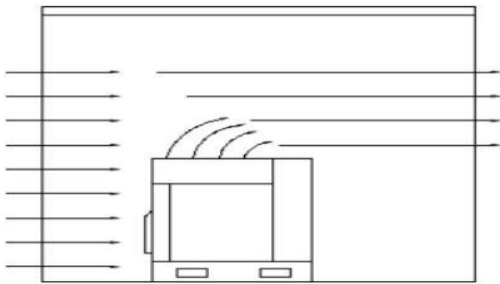
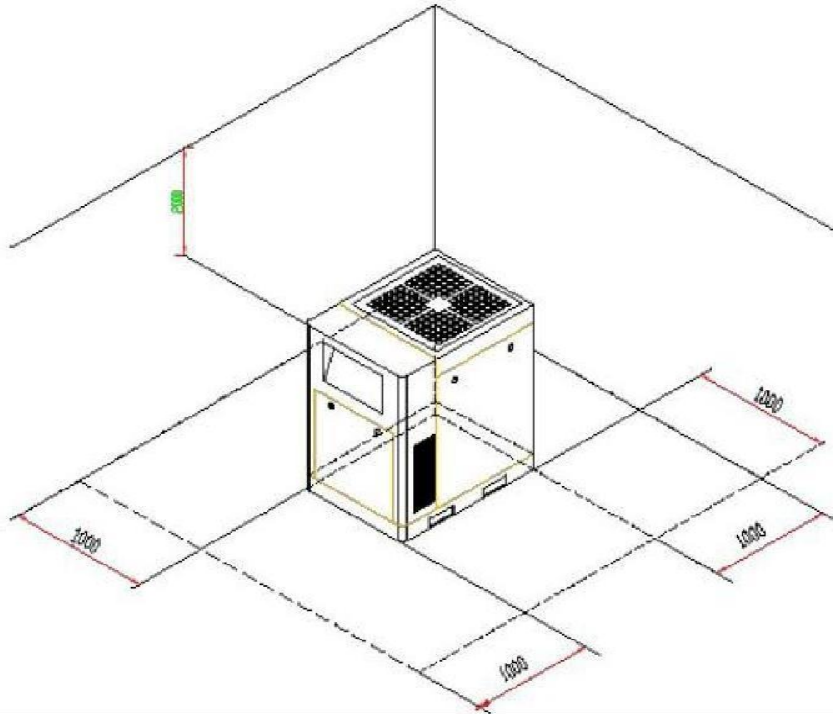

(a)

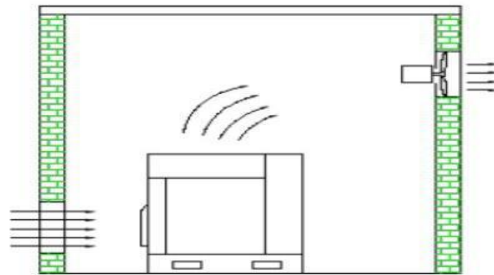

(b)

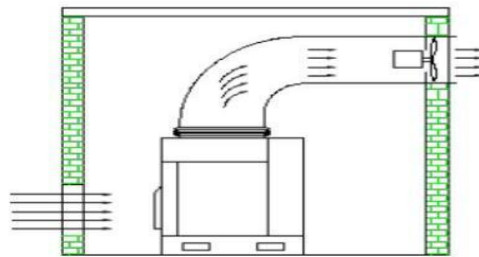

(c)

## 10

## Equipment Operation

1. Before use, loosen the transportation shockproof fixing bolts.
2. The air compressor should be equipped with a suitable gas storage tank before it can be put into use.
3. New machine commissioning

The test voltage according to item 9.1-a shall meet the relevant regulations, the ground wire shall be

connected according to the requirements of item 9.1-d, and the power cord shall be connected according to the requirements of 9.1-b and c. The cross-sectional area and length of the power cord shall meet the requirements of Table 2. Regulations.

Check whether the oil level in the oil cylinder is between the upper and lower limit lines.

To ensure the safety of start-up, first confirm that there are no persons, foreign objects, tools, or other flammable and explosive materials in the unit.

First add about 0.2 liter special lubricating oil to the air compressor (or release it from the oil and gas cylinder) into the intake valve, and turn the machine head for a few revolutions to prevent damage caused by the loss of oil in the air pressure motor static plate when starting (use belt when refueling) Filter funnel to prevent foreign matter from entering the machine head).

Send power to the compressor control panel.

Jog test: before the formal use, the air compressor should be jog 2 to 3 times, that is, start and stop immediately to observe whether the air compressor rotates in the correct direction, and whether there is any abnormal sound and vibration.

Official start operation: press the start button again to start the air compressor operation.

After the equipment is started, the motor is set to start with Y-o, and it starts to run to slowly accelerate in Y-shaped mode. After a few seconds, it will automatically switch to o-shaped mode for rapid acceleration until the normal speed. If there is an abnormal situation, press the stop button to stop the operation.

Stop: Press the stop button to stop the air compressor. The compressed air in the pressure pipeline will be discharged through the unloading valve when the machine is stopped, ready for the next no-load start of the equipment. A slight deflation sound can be heard at this time, which is normal.

#### 4. safety protection

##### Motor protection

No.	Fault conditions	Fault display	Cause
1	Lack of phase	Downtime	Power supply. Contactor. Motor circuit failure
2	overload	Downtime	Increased load or mechanical failure
3	Stall	Downtime	Increased load or mechanical failure
4	unbalanced	Downtime	The three-phase voltage of the power supply is unstable or the motor circuit is faulty
5	Short circuit	Downtime	Serious leakage, short circuit between motor turns or wrong current setting

## Exhaust (oil) over-standard protection

When the exhaust (oil) temperature reaches the set alarm temperature, the controller will display a prompt message and give an alarm. When the temperature reaches the set stop temperature, the controller executes the command and stops. When the phase sequence of the three-phase power supply connected to the air compressor is different from the phase sequence set by the controller, the controller cannot output the start signal and the motor cannot start. At this time, you only need to exchange the two-phase power cord and watch the motor rotation direction.

## Exhaust pressure overpressure protection

When the exhaust pressure is higher than the set high limit, the controller will execute the command and stop.

## Sensor failure protection

When the pressure sensor or temperature sensor is disconnected, the controller will execute the command and stop.

# 11 Use and Maintenance

## 1、Daily use and maintenance (according to Table 5)

### Inspection and maintenance before starting up

- a) Check and keep the equipment clean and complete.
- b) Check and keep the electrical components in good condition and the connections firmly.
- c) Check and keep the fasteners securely locked.
- d) Check and adjust, belt tightness, replace if necessary.
- e) Check, adjust, and replace the coupling or buffer block if necessary.
- f) Check, add and replace lubricating oil if necessary.

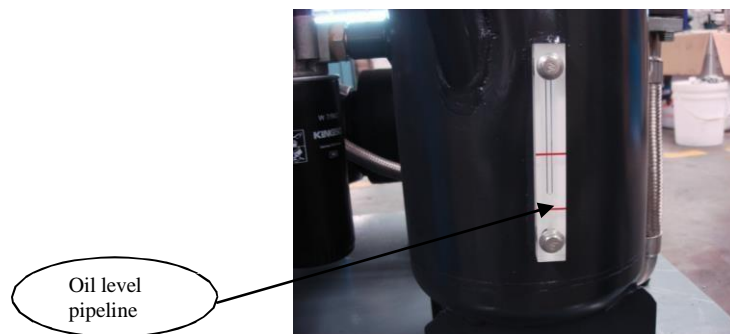

*Picture 11.1 The oil level should be kept between the upper and lower red lines of the oil mark*



Refueling should be filtered through a clean funnel (filter accuracy is 12um)

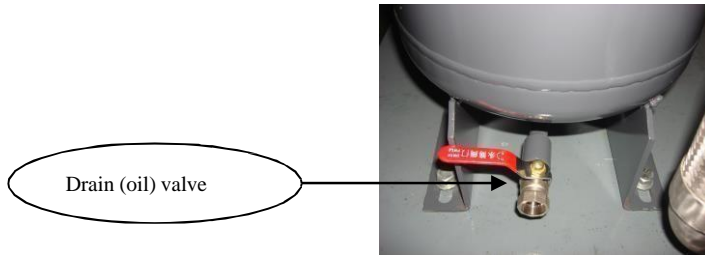

*Picture 11.2 If the lubricant is changed, the old oil must be drained clean*

Check, if necessary, drain the condensed water in the oil and gas cylinder (open the drain valve at the bottom of the oil and gas cylinder slightly to drain the condensate until the lubricating oil flows out).

g) Check, clean, and replace the filter element of the air filter if necessary

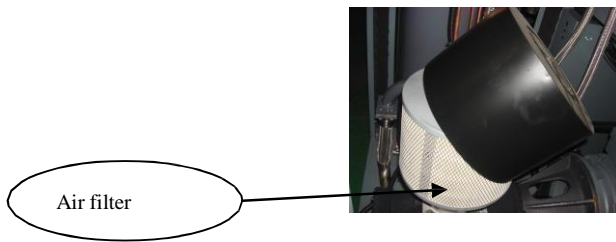

*Picture 11.3*

h) Check, clean, and replace the oil separator if necessary

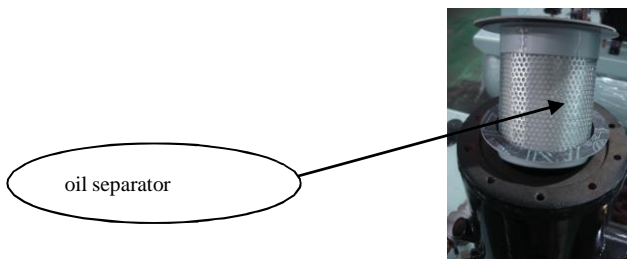

*Picture 11.4*

i) Check, clean, and replace the if necessary

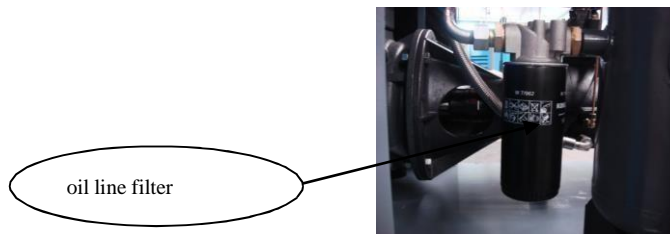

Picture 11.5

j) Check and clean the cooler if necessary

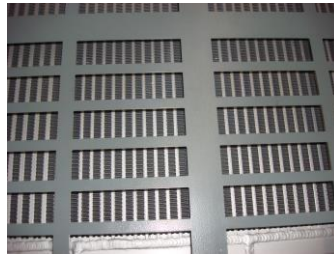

Picture 11.6

## 2、 Check at boot

- a) Check whether the operation button is normal
- b) Check for abnormal noise, vibration, air leakage and oil leakage.
- c) Check whether the pressure gauge, oil thermometer, ammeter and indicator light are normal.
- d) Whether the oil return of the oil return pipe is normal.
- e) Check whether the automatic stop pressure and automatic start pressure are normal (there is a difference between a pressure sensor and a pressure gauge)
- f) Check whether the unloading valve is deflated during shutdown.
- g) Check whether the exhaust temperature is normal.
- h) Check whether the voltage and current are normal.



Picture 11.7

- i) Check, clean, and replace the safety valve if necessary.
- j) Check the insulation resistance of the motor.
- k) Record voltage, current, air pressure, exhaust temperature and oil level every day, and record working

hours, maintenance conditions and abnormal conditions in each shift.

**Maintenance planning**

**table 5**

No.	Check item	Work content	Maintenance cycle						Remarks
			Check every day	Check every week	Check every month	Check every six month	Minor repairs every year	Moderate repairs every two years	
1	fastener	Check bolts and transmission parts	☆						Bolts and transmission parts will not fall off and loosen
2	Coupling	Check the coupling	☆						Normal concentricity, no damage
3	Return pipe strainer	Check the filter			★				No debris
4	Oil return of transparent oil return pipe	Make sure the oil return is normal	☆						Smooth oil return
5	Unloading valve	Confirm shutdown and bleed	☆						Normal unloading and deflation during shutdown
6	lubricating oil	Check the oil level and quality	☆						The oil level should be within the warning line, without oxidation and discoloration
7	Exhaust (oil) temperature	Determine exhaust temperature	☆						Temperature 70-105°C is normal
8	Voltage and current	Check voltage and current	☆						Within 1.2 times of the rated current
9	air filter	Cleaning		☆					Only change the filter element
10	Oil and gas cylinder drainage	Drain water		☆					Drain from the drain valve
11	Dust net	Cleaning and maintenance			☆				Take out and clean
12	Piping system	Check for oil leaks	☆						No oil leakage
13	electrical system	Line terminal or display information	☆						There is no prompt message and the wire falls off
14	Oil filter	Check cleaning			☆				Only replace the filter element
15	Oil and gas separator filter element	Cleaning and replacement			★				Only replace the filter element
16	Host mechanical seal	Check for leaks	☆						Oil leakage is less than 1.5g/h
17	Motor insulation	Check insulation resistance					★		More than 2MΩ at 500V

18	Safety valve	Check action sensitivity				☆			Under the condition of rated pressure, pull the discharge ring of the safety valve with less than 1Kg force to discharge and remove foreign matter
19	Automatic shutdown and start pressure	Check action sensitivity	☆						Stop pressure, start pressure is normal
20	Cooler	Maintain and clean	☆						Clean surface dirt by blowing air
21	Oil level indicator	Check for clarity	☆						Replace when the oil level is not clear
22	Belt, pulley	Check tightness or replace	☆						the center of the belt with your thumb to ensure that it is between 10 and 15mm and no damage

*Note: "☆" in the table is the user maintenance work item, and "★" is the maintenance item of the entrusted service center. A "α" sign means that the new machine must be replaced after 500 hours of continuous operation, and replaced after 3000 hours. The machine has a working time of 6000 Hours a year and the following are maintenance items.*

### 3、 Treatment methods for long-term downtime

When parking for a long time, the equipment should be sealed up.

- a) Clean up the equipment and apply appropriate amount of anti-rust oil to the parts that are easy to rust
- b) Electrical equipment such as the motor control panel and all valves, meters and indicators are wrapped in plastic paper or oil paper.
- c) Drain the water in the oil cooler (gas cylinder), gas cooler and gas storage tank clean
- d) Wrap the whole equipment with plastic paper or similar items.
- e) If the storage site is to be transferred, the transportation fixing screws should be tightened.

To restart the sealed air compressor, first measure the insulation resistance of the motor (not less than 1 Ω) and then follow the operating instructions. Lubricating oil should be replaced for air compressors that have been sealed for more than one year.

# 12

# Troubleshooting

table 6

No.	Fault conditions	Fault display	Cause
1	The motor cannot start	No voltage input or abnormal voltage	Check the power circuit
		Phase loss (the motor makes a "buzzing" sound)	Check the power cord terminal and the electric controller and the connection terminal
		The power phase is connected incorrectly or the main controller is faulty	Change the phase sequence and overhaul or replace the main controller
		Fuse blown	After confirming that the inspection circuit is correct, replace the fuse
		AC contactor contacts burn out or malfunction	Repair or replace
		The pressure switch (pressure sensor) fails	Repair or replace
		Motor burns out, bearing damage	Overhaul or replace
		Blocked rotor caused by stuck moving disk or damaged bearing	Overhaul or replace
		Temperature sensor action protection	Find out the cause and troubleshoot
		Current protector action protection	Find out the cause and troubleshoot
2	<b>Motor starts frequently</b>	Start delay is out of control	Check or reset the delayer and main controller and replace
		The pipeline leaks seriously	Check the leak and eliminate it
		The volume of the gas tank is not large enough	Increase gas storage tank or replace larger gas storage tank
3	<b>Exhaust (oil) temperature is too high</b>	The ambient temperature is too high	Increase the ventilation of the computer room
		The cooler is too dirty and poor heat dissipation	Clean the cooler
		Blocked oil circuit	Check and clear
		Temperature sensor failure	Overhaul and replacement
		Not enough lubricating oil	Increase lubricant
		Cooling fan failure	Check or replace
4	<b>Low exhaust pressure</b>	Pressure switch, force sensor, main controller failure	Overhaul, adjust or replace
		Excessive gas consumption	Overhaul pipelines, add air compressors or control air consumption
		The pipeline leaks seriously	Overhaul, replace if necessary
		Air filter is clogged	Clean or replace the filter element
		Inlet valve failure	Overhaul or replace
		Oil and gas separator blocked	Clean or replace
		Leakage of unloading solenoid valve	Overhaul or replace
		Turn the V belt to slip	Check, adjust, replace
Large consumption of lubricating oil	Oil return pipe blocked	Clean or replace	
	Oil and gas separator over maintenance period	Clean or replace	

5		Lube oil level is too high	Lower the oil level
		Minimum pressure valve failure	Overhaul or replace
		No special lubricant is used	Exchange special lubricants
6	Abnormal sound and vibration	Loose fasteners, motor or host bearing wear or damage	Overhaul or replace
		Belt wear	Replace belt
		Worn or loose coupling	Check, tighten or replace
		Rotating parts such as the machine head, motor, or fan enter foreign matter	Overhaul or replace
7	Premature deterioration of lubricating oil	The old lubricant is not drained	Drain the old oil and replace with new special lubricant
		No special lubricant is used	Change special lubricant
		Exhaust temperature is too high	Increase ventilation, reduce ambient temperature or repair temperature control valve and cooling system
8	When shutting down, the air filter leaks oil	Inlet valve failure	Overhaul or replace
		Minimum pressure valve return air	Overhaul or replace
		The unloading solenoid valve does not deflate	Overhaul or replace
9	The motor rotates slowly, causing high current or tripping	Machine head, motor and its bearing failure	Overhaul or replace
		Drive V belt is too tight	Check and adjust the nose
		Low input voltage (the wire is too long and the wire diameter is too small)	Adjust the wire
		Poor circuit connection	Overhaul or replace
		The pipeline pressure difference is too large (filter element is blocked)	Overhaul or replace
		Three-phase voltage is seriously unbalanced	Check and rule out
		Poor contact or insufficient switch current capacity	Overhaul or replace
		No special lubricant is used	Change special lubricant
10	The cooling fan does not rotate	The temperature is too high, the current is too large, the overload protector operates	Overhaul and replacement
		Lack of phase	Check circuit and AC contactor
		Thermostat or main controller failure	Overhaul or replace
		Three-phase resistance value does not match (motor burned out)	Overhaul or replace
		Fan bearing failure	Overhaul or replace